



TYRE CHANGER

F 528S GT

07-2020 Rel.1



SPARE PARTS LIST

UK

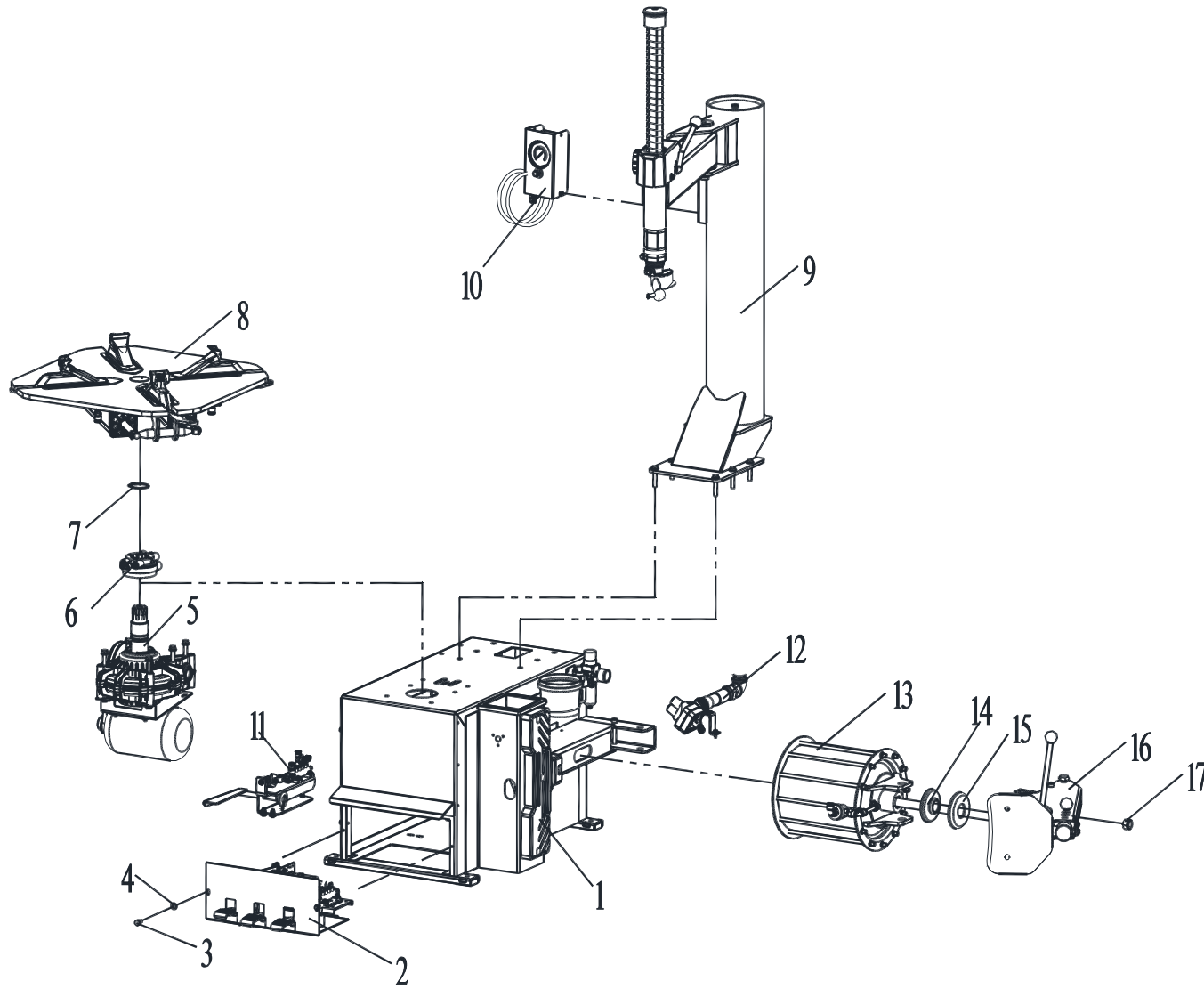

TAV.0.2**TIRE CHANGER ASSEMBLY**

ITEM	PART NUMBER	DESCRIPTION	QTY	REMARK
1	104-2001000M	Shell	1	
2	YC1-2005000	Pedal control unit	1	
3	0201011	Screw M6X12	2	
4	0205007	Washer D.6	2	
5	YC1-2002000	Motor – Reduction gear group	1	
6	YC2-4298992	Rotation union GT	1	
7	0212009	Seeger D.50 - GB/T894.1	1	
8	104-2007000M	Turntable	1	
9	104-2004000M	Horiz. And vert. Arms	1	
10	YC2-2014217A	Pressure gauge	1	
11	YC2-2012486	GT pedal control unit	1	
12	104-2008001	Quick charge valve assembly	1	
13	C00AQ10000	Bead breaker cylinder	1	
14	106B-3006001	Shock absorber	1	
15	106B-3006002	Absorber protection	1	
16	104-2006000	Bead breaker arm assembly	1	
17	0204009	Self-locking nut M18	1	

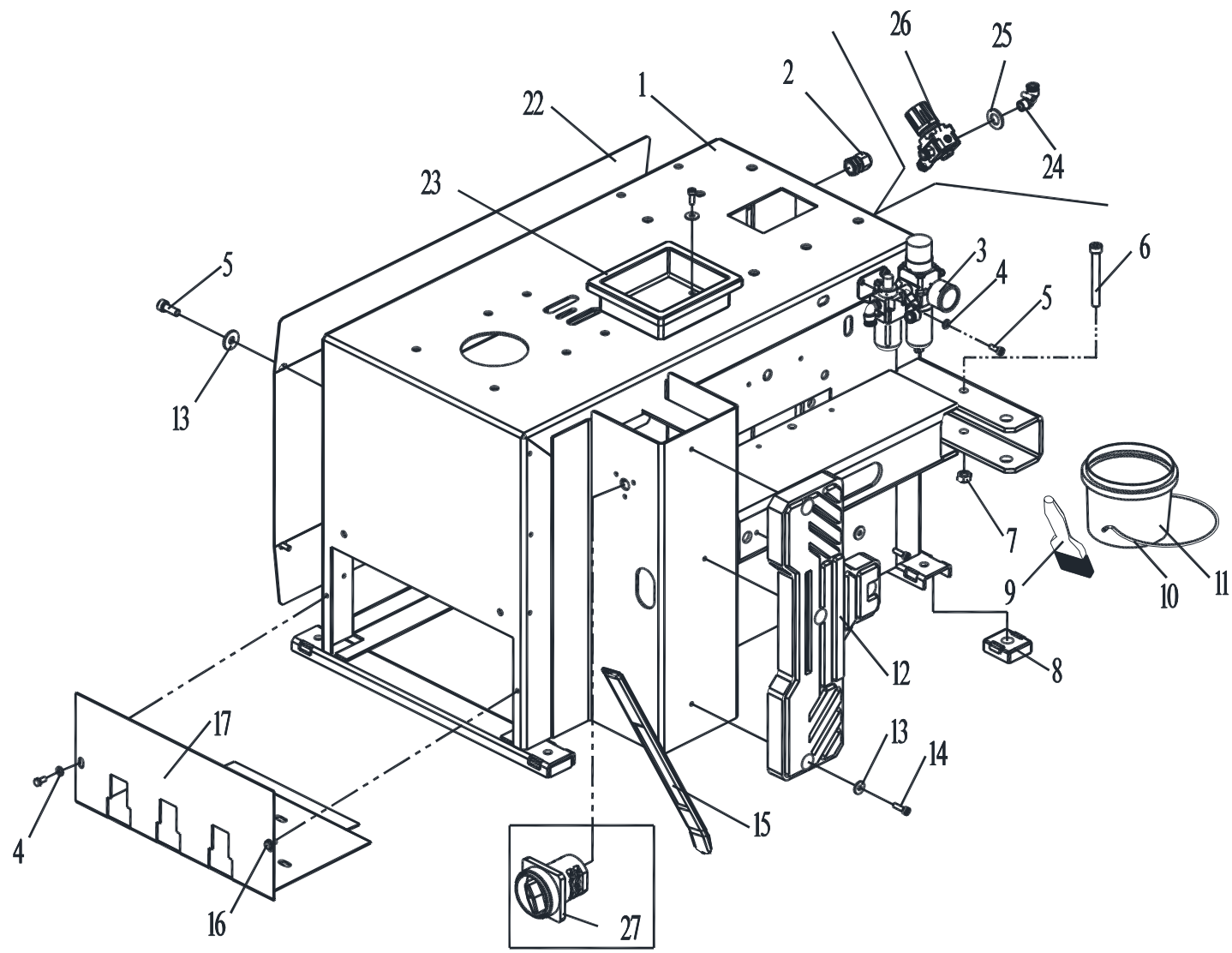

TAV.1.0	BODY	
----------------	-------------	--

ITEM	PART NUMBER	DESCRIPTION	QTY	REMARK
1	106B-2401001	Shell	1	
2	0508252	Cable relief	1	
3a	C00AQ52000	SMC lubricator + filter regulator	1	
3b	C00AQ53000	SMC lubricator + filter regulator(Quick union)	1	
4	0205006	Washer D.6 - GB/T97.1	4	
5	0202032	Screw M6X16 - GB/T70.1	7	
6	0202067	Screw M10X85 - GB/T70.1	1	
7	0204005	Nut M10 - GB/T889.1	1	
8	YC1-3002099	Plastic foot	4	
9	0511063	Grease brush	1	
10	YC1-3000069	Spring	1	
11	YC1-4299984	Grease cup	1	
12	YC1-3002102	Wheel support	1	
13	0205007	Washer D.6 - GB/T96	8	
14	0202033	Screw M6X20 - GB/T70.1	4	
15	0511242	Bead lifting lever	1	
16	0201011	Screw M6X12 - GB/T5783	2	
17	YC1-3012080	Pedal support	1	
22	YC1-3001800	Side cover	1	
23	202W-3018260	Plastic cover	1	
24	0306034	90° union 8-1/8	1	
25	0205013	Washer D.12 - GB/T97.1	2	
26	C00AQ58000	Safety valve unit 3.5bar	1	Optional

TAV.1.0	BODY			
---------	------	--	--	--

27

0505008

Dual speed switch

1

Optional

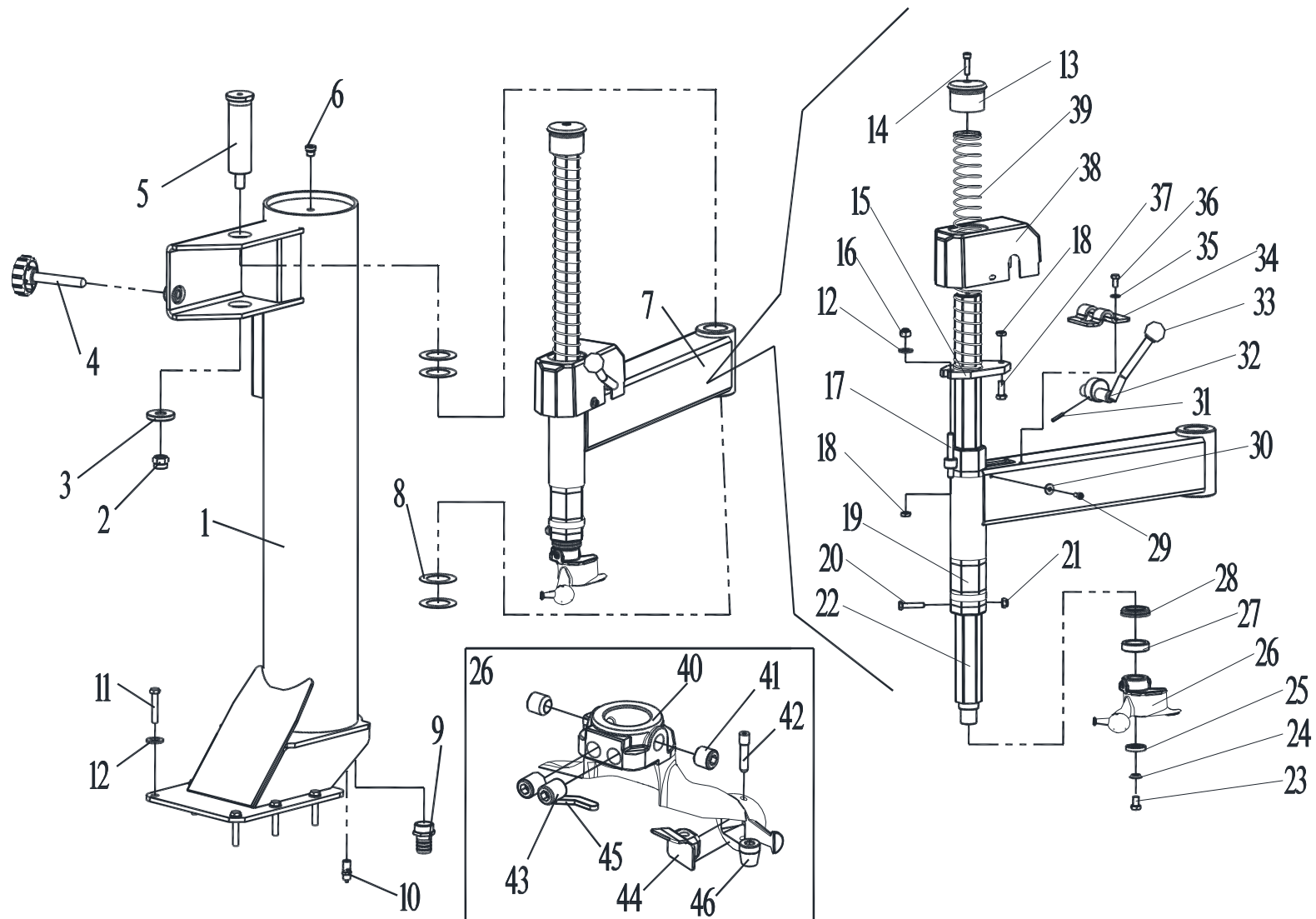

TAV.2.0

HORIZ. AND VERT. ARMS

ITEM	PART NUMBER	DESCRIPTION	QTY	REMARK
1	104-2412737M	Vertical post	1	
2	0204008	Self-locking nut M16 - GB/T889.1	1	
3	104-3000079	Washer	1	
4	YC1-2004002	Hand wheel	1	
5	104-3000078-A	Pivot	1	
6	0305019	Plug	1	
7	104-2004001	Horizontal arm assembly	1	
8	104-4399962	Steel shim	4	
9	0306134	Union 1"	1	
10	0306004	Safety valve 1/4 10bar	1	
11	0201055	Screw M10X55 - GB/T5782	6	
12	0205011	Washer D.10 - GB/T97.1	7	
13	YC1-3001759	Arm knob	1	
14	0202049	Screw M8X30 - GB/T70.1	1	
15	104-3002366-D	Arm locking plate	1	
16	0204005	Nut M10 - GB/T889.1	2	
17	0213042	Screw M10X80	1	
18	0204012	Nut M10 - GB/T6172.1	2	
19	104-2406658-F	Horizontal arm	1	
20	0201037	Screw M8X40 - GB/T5782	1	
21	0204004	Nut M18 - GB/T889.1	1	
22	104-3002365-H	Hexagonal arm	1	
23	0201062	Screw M10X20 - GB/T5783	1	
24	YC1-4295805	Spherical washer	1	
25	YC1-4295804	Conical washer	1	
26	YC1-2002215	Mounting tool unit	1	
27	YC1-3002601	Shock absorber	1	

TAV.2.0	HORIZ. AND VERT. ARMS		
---------	-----------------------	--	--

28	YC1-3002602	Shock absorber protection	1
29	0202024	Screw M6X12 - GB/T70.1	2
30	0205007	Washer D.6 - GB/T96	2
31	0213003	Pin 4X25 - GB/T879.1	1
32	104-2406664-B	Arm locking lever	1
33	YC1-4299952	Knob	1
34	104-3006663	Fulcrum plate	1
35	0205008	Washer D.8 - GB/T97.1	2
36	0201026	Screw M8X16 - GB/T5783	2
37	0201064	Screw M10X25	1
38	104-3006662-A	Arm frame	1
39	104-3005407	Spring	1
40	YC1-3007801	Mounting tool	1
41	0209020	Screw M12X12 - GB/T80	2
42	0215031	Shaft	1
43	YC1-3006689	Plastic insert	1
44	YC1-3013650	Plastic insert	1
45	0209015	Screw M12X16 - GB/T80	2
46	0215032	Peak roll	1

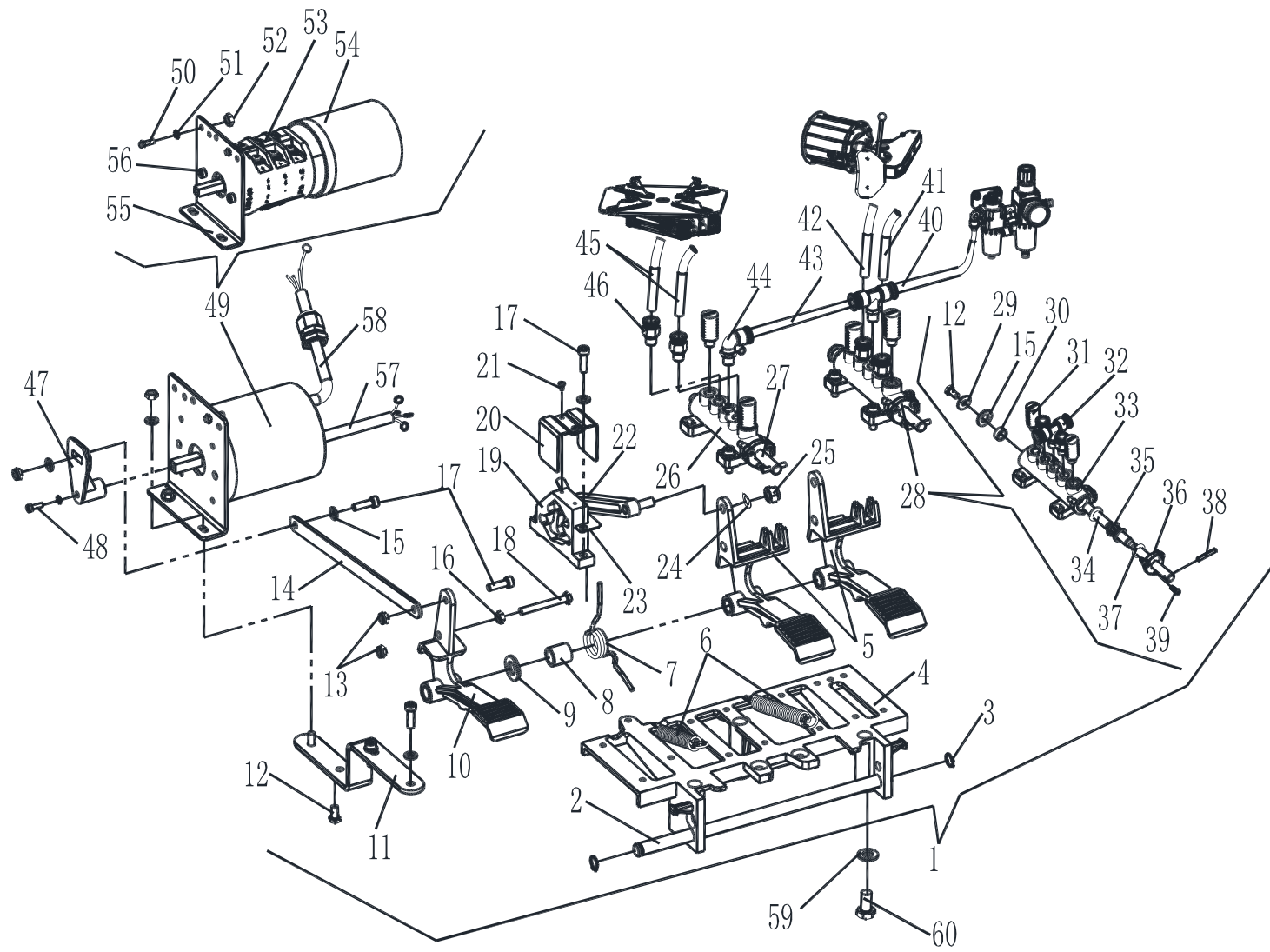

TAV.3.0	PEDAL BOX	
----------------	------------------	--

ITEM	PART NUMBER	DESCRIPTION	QTY	REMARK
1	YC1-2015861	Pedal control unit	1	
2	YC1-3003094	Pedal alignment pin	1	
3	0212001	Seeger D.12 - GB/T894.1	2	
4	YC1-3002161	Pedal box base	1	
5	YC1-3002159	Pedal B	2	
6	YC1-3013333	Pedal return spring	2	
7	C00A000001	Spring	1	
8	YC1-3007953	Bush	1	
9	0205013	Washer D.12 - GB/T97.1	1	
10	YC1-3002157	Pedal A	1	
11	YC1-3015342	Support	1	
12	0201011	Screw M6X12	3	
13	0204003	Nut M6 - GB/T889.1	3	
14	YC1-3015341	Connection rod	1	
15	0205006	Washer D.6 - GB/T97.1	12	
16	0203004	Nut M6 - GB52	3	
17	0202033	Screw M6X20 - GB/T70.1	10	
18	0201016	Screw M6X50 - GB/T5782	1	
19	YC1-4299913	Double cam	1	
20	YC1-3099910	Connection rod guide	1	
21	0207034	Self-tapping screw ST2.9X6.5 - GB/T845	2	
22	YC1-4299912	Connection rod	1	
23	YC1-4299911	Forked leaf spring	1	
24	0215019	Washer D.8 - GB/T860	2	
25	0204004	Nut M8 - GB/T889.1	1	
26	YC1-2002529	Turntable valve unit	1	
27	YC1-3002442	Valve pin 1	1	

TAV.3.0

PEDAL BOX

28	YC1-2006297	Bead breaking valve unit	1
29	0205007	Washer D.6 - GB/T96	1
30	YC1-4197629	Nylon washer	1
31	0306059	Silencer 1/8	4
32	0306023	Quick T union 8-1/8	1
33	YC1-3001583	Valve body	2
34	YC1-3007598	Valve pin 3	1
35	YC1-3001584	Valve spacer	10
36	YC1-3001585	Valve flange	2
37	YC1-4299000	O-ring 17X4	12
38	0213003	Elastic pin 4X25 - GB/T879.1	2
39	0207032	Self-tapping screw ST3.5X13 - GB/T845	6
40	0306097	Rilsan hose 8X5 L=1000	1
41	0306097	Rilsan hose 8X5 L=700	1
42	0306097	Rilsan hose 8X5 L=800	1
43	0306097	Rilsan hose 8X5 L=70	1
44	0306033	90° quick union 8-R1/8	1
45	0306097	Rilsan hose 8X5 L=850	2
46	0306045	Quick union 8-1/8	4
47	YC1-3000175	Reverser lever	1
48	0202004	Screw M4X12 - GB/T70.1	1
49	YC1-2002002	Reverser assembly	1
50	0201004	Screw M4X12 - GB/T5781	2
51	0211016	Washer D.4 - GB/T862.2	2
52	0203002	Nut M4 - GB52	2
53	0505009	Reverser 40A	1
54	YC1-3015344	Reverser cover	1

TAV.3.0	PEDAL BOX		
---------	-----------	--	--

55	YC1-3015340	Reverser support	1
56	0202021	Screw M5X20 - GB/T70.1	2
57	0506016	Motor cable L=1500	1
58	0506016	Power cable L=3500	1
59	0205008	Washer D.8 - GB/T97.1	3
60	0201026	Screw M8X16 - GB/T5783	3

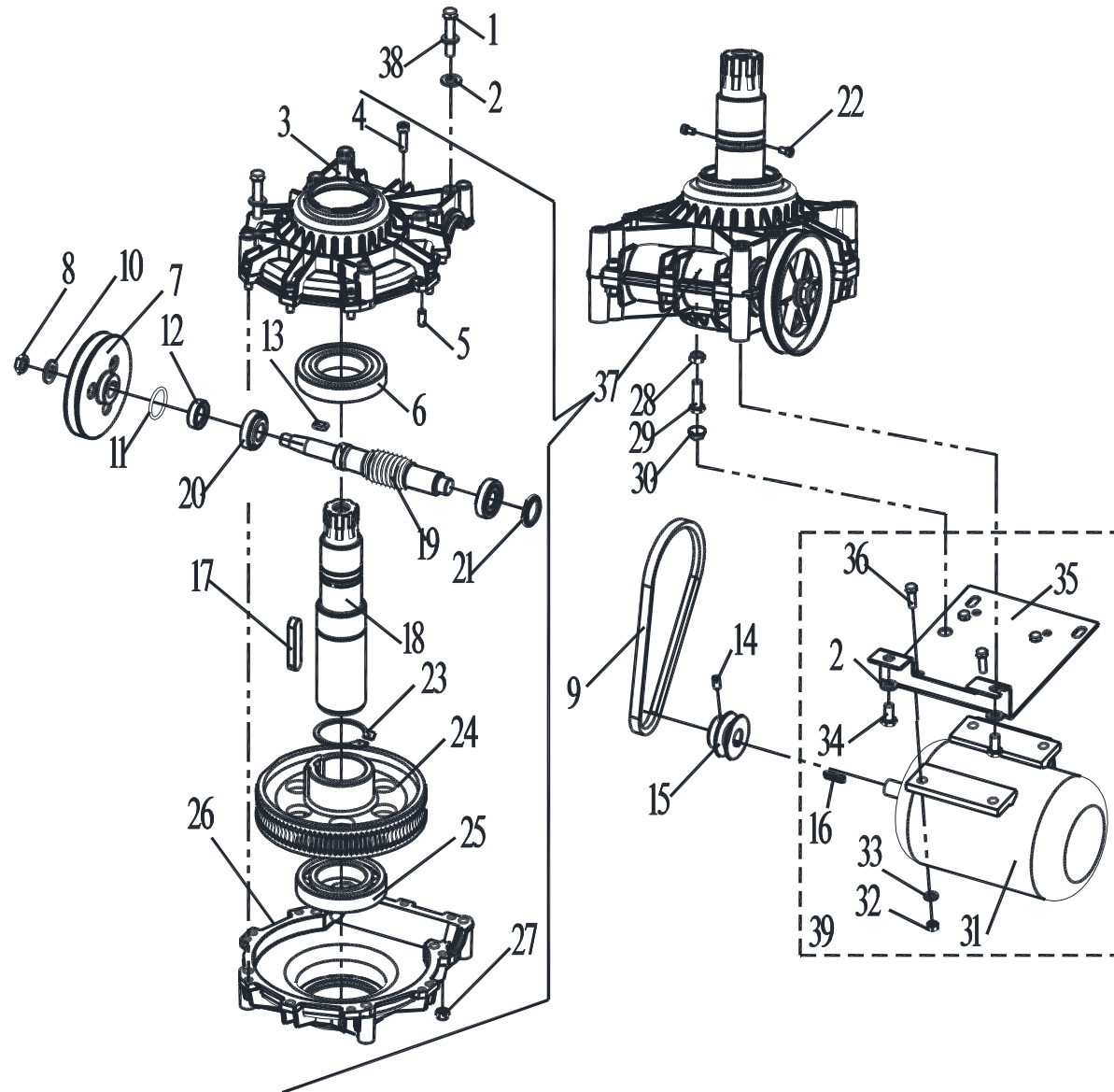

TAV.4.0	MOTOR – REDUCTION GEAR GROUP	
----------------	-------------------------------------	--

ITEM	PART NUMBER	DESCRIPTION	QTY	REMARK
1	0201069	Screw M10X55 - GB/T5780	6	
2	0205011	Washer D.10 - GB/T97.1	8	
3	YC1-3010872	Top gear box	1	
4	0202049	Screw M8X30 - GB/T70.1	10	
5	0213011	Elastic pin 8X20- GB/T119.1	2	
6	0214006	Bearing 6212-2RS - GB/T276	1	
7	YC1-3199596	Gear box pulley	1	
8	0204013	Nut M14 - GB/T6172.1	1	
9	0511052	V belt A580	1	
10	0205017	Washer D.14 - GB/T97.1	1	
11	0606005	O-ring 34.5X3.55 - GB/T3452.1	1	
12	YC1-4296942	Seal	1	
13	0213028	Tab 6X18 - GB/T1096	1	
14	0209009	Screw M8X16 - GB/T80	1	
15	YC1-3000166	Motor pulley	1	
16	202W-ZYDJPJ	Tab 6X30 - GB/T1096	1	
17	0213027	Tab 16X70 - GB/T1096	1	
18	YC1-3010885	Helical gear stud	1	
19	YC1-3010883	Worm	1	
20	0214007	Bearing 30204 - GB/T297	2	
21	YC1-3010886	Seal cap	1	
22	0202030	Screw M6X10 - GB/T70.1	2	
23	0212010	Seeger D.60 - GB/T894.1	1	
24	YC1-3015537	Helical gear	1	
25	0214005	Bearing 6212 - GB/T276	1	
26	YC1-3010873	Bottom gear box	1	
27	0204004	Nut M8 - GB/T889.1	10	

TAV.4.0	MOTOR – REDUCTION GEAR GROUP	
---------	-------------------------------------	--

28	0203009	Nut M10 - GB52	1
29	0201050	Screw M10X35 - GB/T5783	1
30	YC1-3000164	Spherical washer	1
31a	41200138	Motor 110V MI	1
31b	20200658	Motor 220V MI	1
31C	0509017	Motor 380V/50HZ/3ph 0.8/1.1KW	1
		Nut M8 - GB/T6170	1
32	0203029	Washer D.8 - GB/T97.1	4
33	0205008	Screw M10X20 - GB/T5783	4
34	0201062	Screw M10X20 - GB/T5783	2
35	YC1-3000149A	Motor support	1
36	0201038	Screw M8X25 - GB/T5783	4
37	YC1-2011967	Reduction gear unit	1
38	0208007	Washer D.10 - GB/T93	6
39	YC1-2002001	Motor unit	1

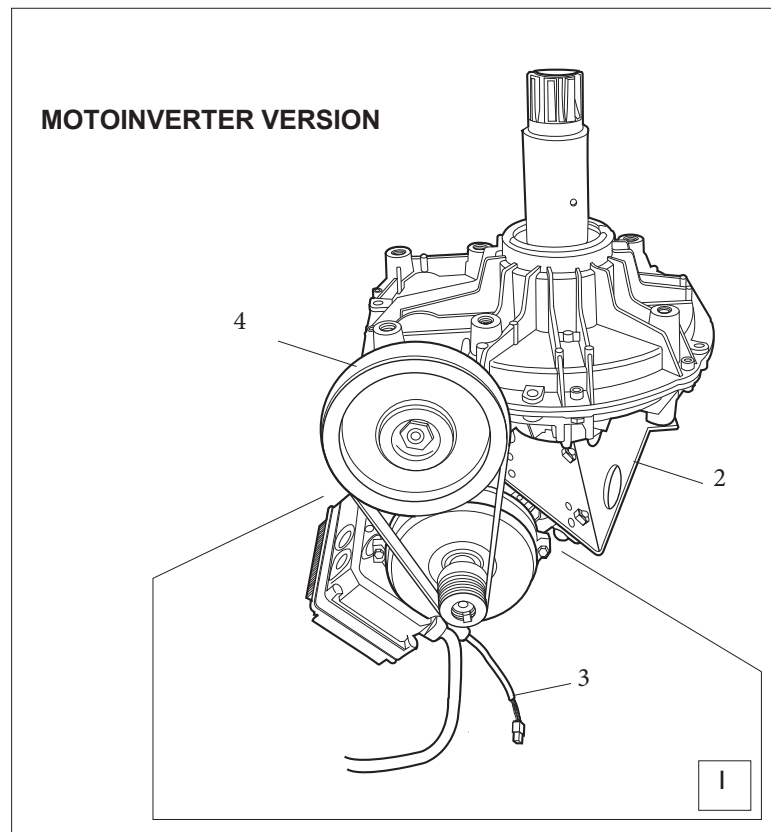

Ref.	Code	Description
1	20200658	MOTOINVERTER 2 SPEED 230V/1/50-60HZ
2	90003054	MOTOINVERTER SUPPORT
3	20200763	COMMAND CABLE MOTOINVERTER
4	90003337	MOTOR BELT 2 SPEED

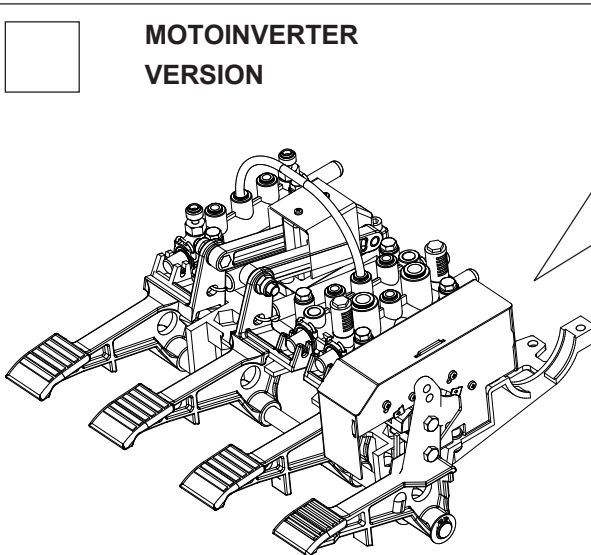
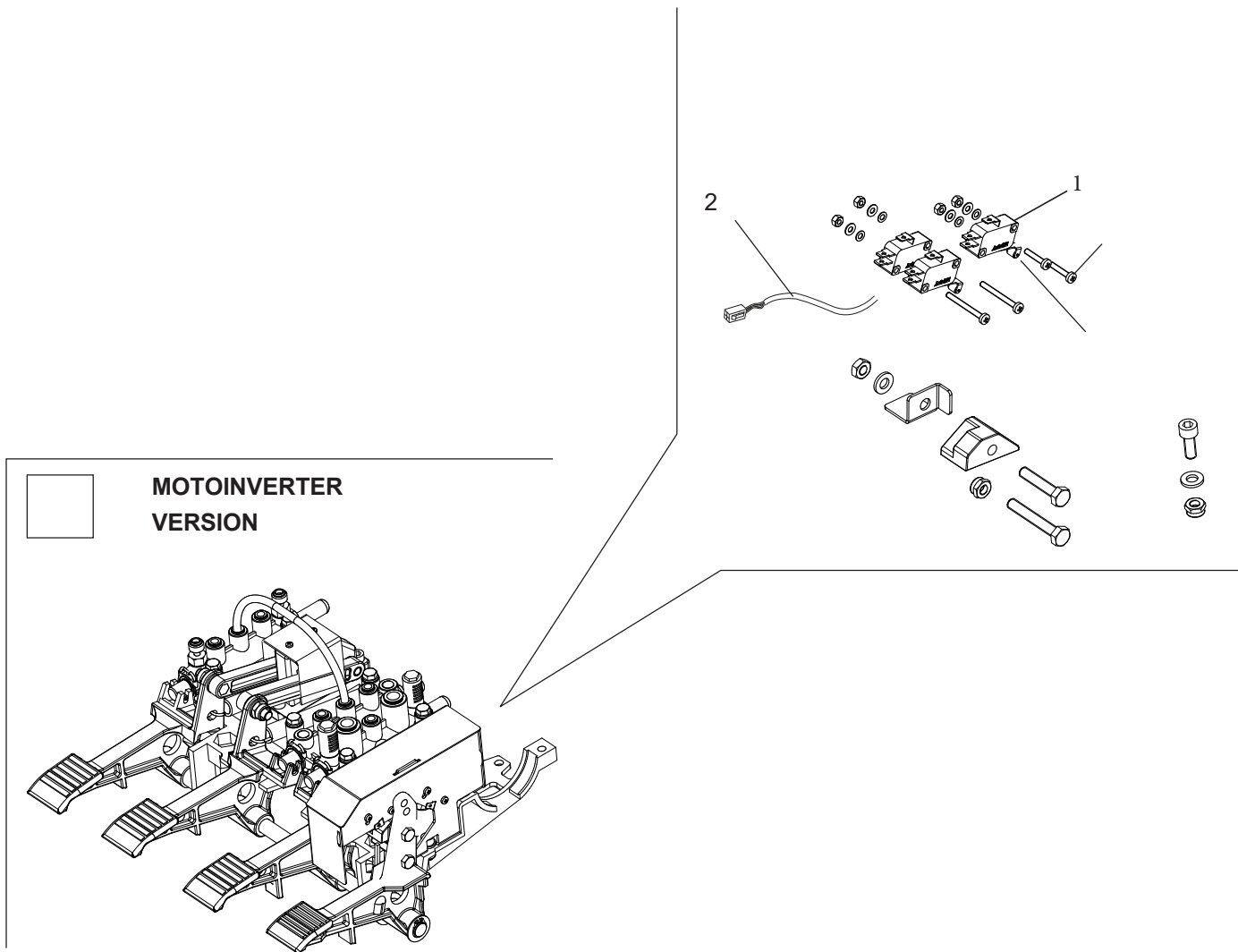

- 1 21200351
- 2 20200763

MICRO 16A 250V
CABLE

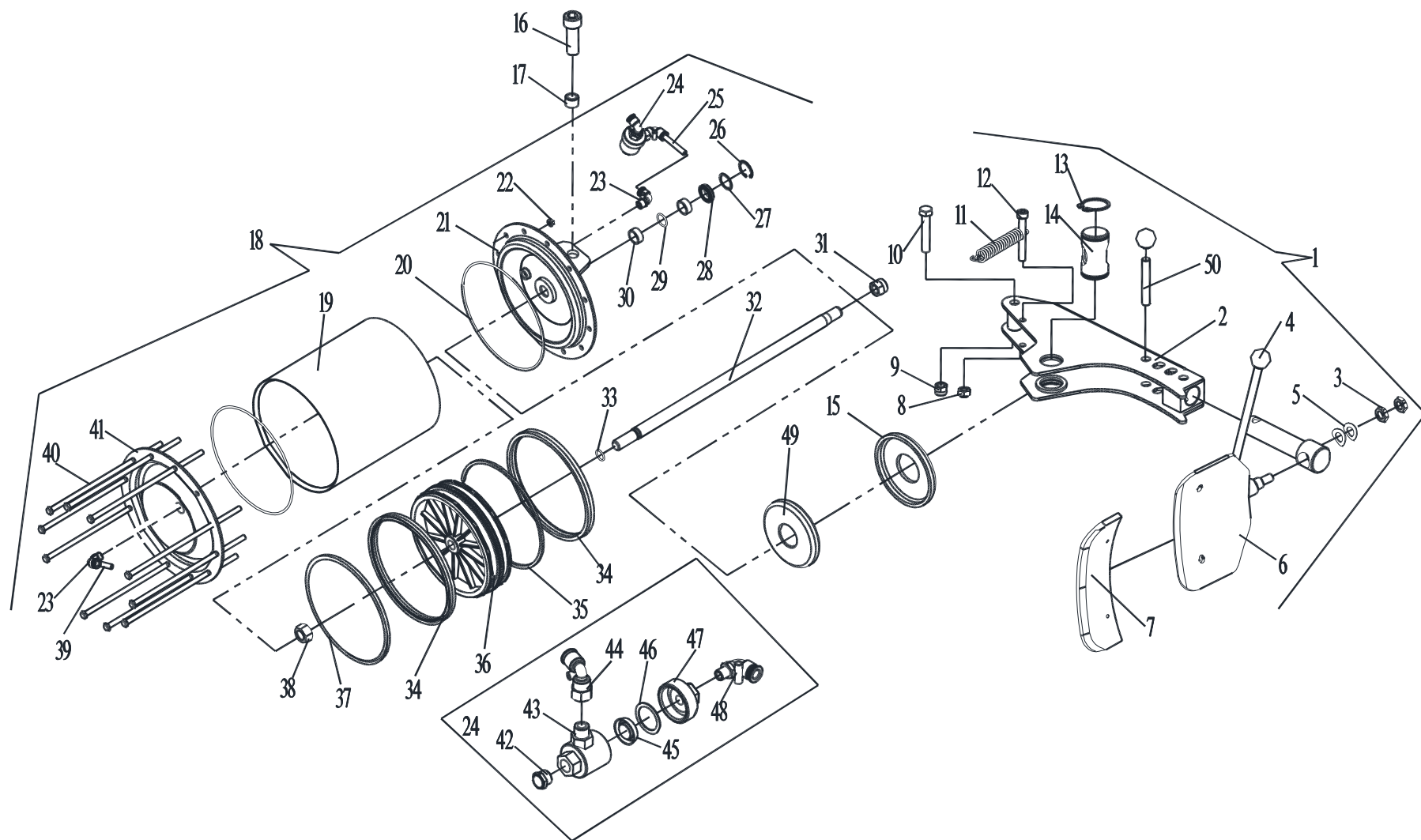

TAV.5.0

BEAD BREAKER

ITEM	PART NUMBER	DESCRIPTION	QTY	REMARK
1	104-2006000	Bead breaker arm assembly	1	
2	104-2419234	Bead break arm	1	
3	0204013	Nut M14 - GB/T6172.1	2	
4	YC1-4299952	Ball	2	
5	0211015	Elastic washer D.14	2	
6	104-2412275-D	Bead breaker arm	1	
7	YC1-3013240	Protection cover	1	
8	0204005	Self-locking nut M10 - GB/T889.1	1	
9	0204008	Self-locking nut M16 - GB/T889.1	1	
10	0201099	Screw M16X90 - GB/T5782	1	
11	YC1-3000114A	Arm spring	1	
12	0202057	Screw M10X70 - GB/T70.1	1	
13	0212008	Seeger D.40 - GB/T894.1	2	
14	YC1-3008990	Pivot pin	1	
15	106B-3006002	Absorber protection	1	
16	0202071	Screw M12X35 - GB/T70.1	2	
17	YC1-3015573	Bush	2	
18	C00AQ10000	Bead breaker cylinder	1	
19	C00AQ10001	Cylinder liner 200X227.5	1	
20	0309104	O-ring 195X3.55	2	
21	C207010100	Front flange	1	
22	0204025	Flange nut M8 - GB/T6177.1	12	
23	0306032	90° quick union 8-1/4	2	
24	C02AQ00100	Quick discharge valve unit	1	
25	0306097	Rilsan hose 8X5 L=700	1	
26	0211004	Seeger D.30 - GB/T893.1	1	
27	YC1-4398146	Washer	1	

TAV.5.0	BEAD BREAKER		
---------	--------------	--	--

28	0606016	Scraper 20X30X7	1
29	0606004	O-ring 20X2.75	1
30	0305041	Guide ring 67X9.5X2	1
31	0204009	Self-locking nut M18 - GB/T889.1	1
32	YC1-3015834-B	Piston rod	1
33	0309084	O-ring 16X2.65	1
34	C207010004	Seal 188X200X12	2
35	C207010001	Guiding ring	1
36	C207010002	Piston	1
37	C207010008	Seal support ring	2
38	0203022	Nut M18X1.5 - GB/T6171	1
39	0306097	Rilsan hose 8X5 L=750	1
40	0201175	Screw M8X248	12
41	C207010007	Back flange	1
42	0306086	Silencer G1/4	1
43	C02AQ00101	Valve body	1
44	0306039	Quick union 8-1/4	1
45	C02AQ00104	Seal	1
46	C02AQ00103	Seal	1
47	C02AQ00102	Valve cover	1
48	0306033	90° quick union 8-R1/8	1
49	106B-3006001	Shock absorber	1
50	104-3013838	Pin(without knob)	1

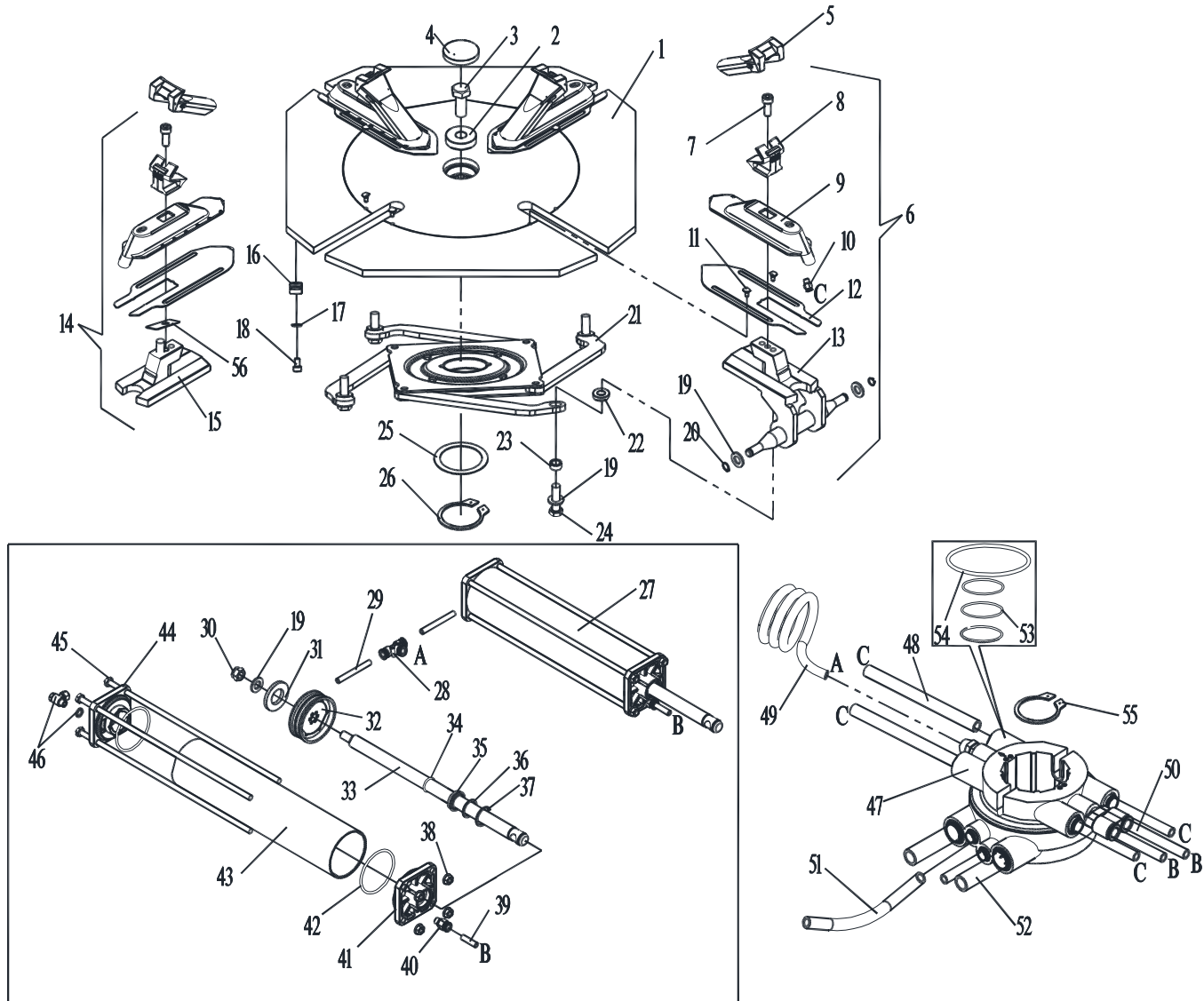

TAV.6.0	SELF-CENTERING TURNTABLE GT	
----------------	------------------------------------	--

ITEM	PART NUMBER	DESCRIPTION	QTY	REMARK
1	104-3019250-A	Turntable	1	
2	YC1-3009778	Washer	1	
3	0201100	Screw M16X1.5X40 - GB/T5786	1	
4	YC1-3000062	Turntable cap	1	
5	YC1-3001468	Clamp cover	4	
6	104-2007003	Clamp assembly	2	
7	0202055	Screw M10X25 - GB/T70.1	4	
8	YC1-3002297	Oversize clamp	4	
9	YC2-2407387	Slide	4	
10	0306042	Quick union 10-1/4	4	
11	YC1-3015187	Rivet	8	
12	104-3015171b	Turntable plate	4	
13	YC1-2415756	Slide guide	2	
14	104-2007002	Slide guide	2	
15	YC1-2412860	Slide guide	2	
16	C00A000016	Clip	4	
17	0205006	Washer D.6 - GB/T97.1	4	
18	0202030	Screw M6X10 - GB/T70.1	4	
19	0205013	Washer D.12 - GB/T97.1	10	
20	0212001	Seeger D.12 - GB/T894.1	4	
21	104-2007001	Turntable flange	1	
22	YC1-3006879	Spacer	4	
23	YC1-3006880	Connection rod spacer	4	
24	0201072	Screw M12X1.25X45 - GB/T5786	4	
25	YC1-3006869-A	Connection rod spacer	1	
26	0212011	Seeger D.65	1	
27	YCP-2008857	Turntable cylinder	2	

TAV.6.0	SELF-CENTERING TURNTABLE GT	
---------	-----------------------------	--

28	0306022	Quick T union D.8	1
29	0306097	Rilsan hose 8X5 L=70	2
30	0204007	Nut M12 - GB/T889.1	2
31	YC1-4198857	Washer	2
32	YC1-4198856	Piston	2
33	YCP-3008859	Piston rod	2
34	0606004	O-ring 20X2.75 - GB/T3452.1	2
35	0606016	Scraper 20X30X7	2
36	YC1-4398146	Washer	2
37	0211004	Seeger D.30 - GB/T893.1	2
38	0204025	Nut M8 - GB/T6177.1	8
39	0306097	Rilsan hose 8X5 L=350	2
40	0306045	Quick union 8-1/8	2
41	YC1-3015024A	Front flange	2
42	0606007	O-ring 75X3.55 - GB/T3452.1	4
43	YCP-3008858	Cylinder liner	2
44	YC1-3015023A	Back flange	2
45	0201035	Screw M8X431	8
46	0306016	Union 8-1/8	2
46	0306016-1	Nylon washer	2
47	YC2-4298992	Rotation union GT	1
48	0306094	Rilsan hose 10X6.5 L=4200	4
49	0306157	Rilsan spiral hose 8X5.5 L=625	2
50	0306097	Rilsan hose 8X5 L=270	2
51	0306097	Rilsan hose 8X5 L=850	2
52	0306018	Rilsan hose 14X10 L=1000	3
53	0309065	O-ring 63X2.65 - GB/T3452.1	1

TAV.6.0	SELF-CENTERING TURNTABLE GT			
---------	-----------------------------	--	--	--

54	0309067	O-ring 90X1.8 - GB/T3452.1	1
55	0212009	Seeger D.50 - GB/T894.1	1
56	0306022	Steel shim	4

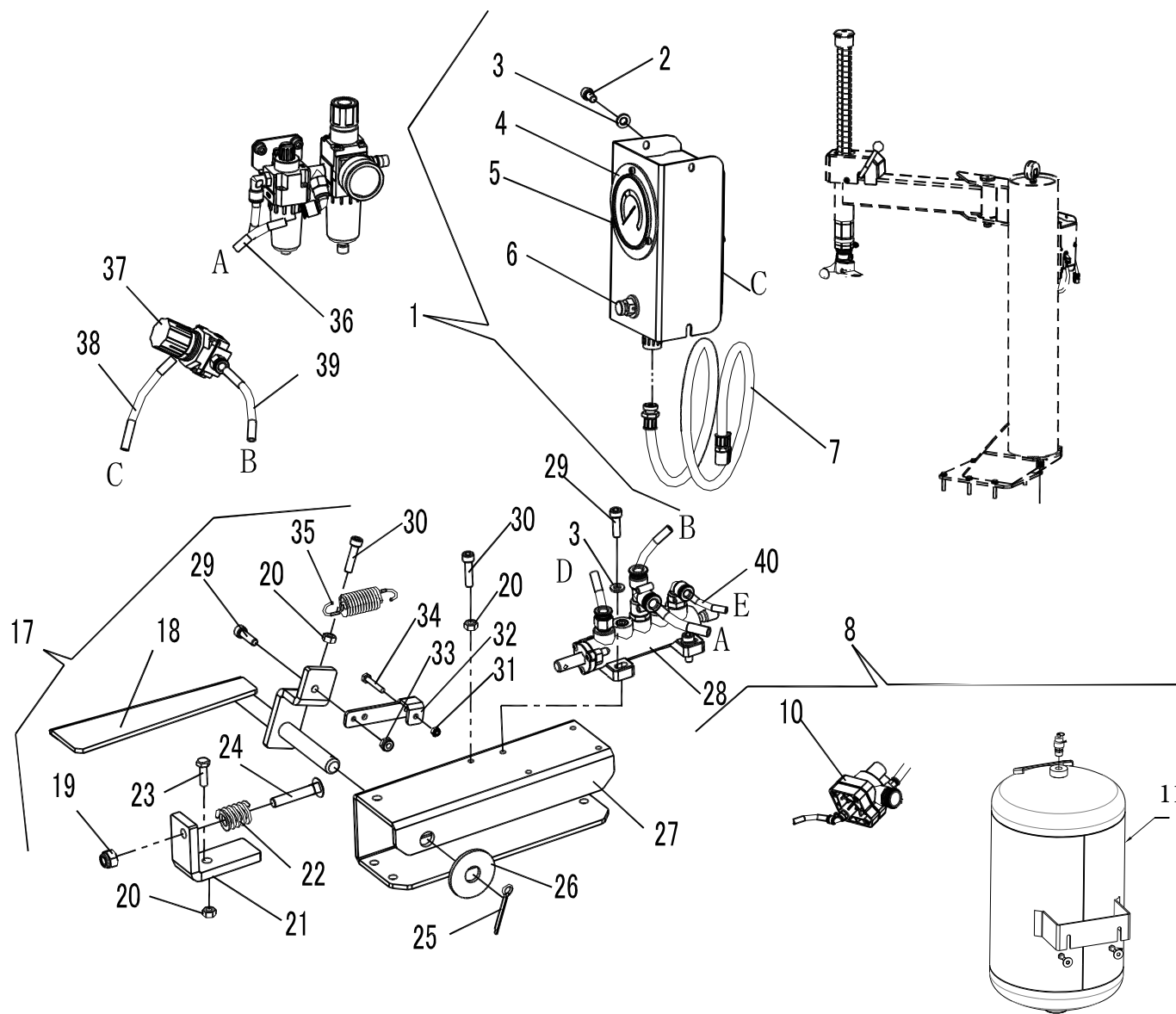

TAV.7.0

GT INFLATING DEVICE

ITEM	PART NUMBER	DESCRIPTION	QTY	REMARK
1	YC2-2014217A	GT pneumatic unit	1	
2	0202030	Screw M6X10 - GB/T70.1	2	
3	0205006	Washer D.6 - GB/T97.1	6	
4	0305058	Pressure gauge	1	
5	0202008	Screw M4X8 - GB/T70.1	5	
6	YC2-4299354	Relief valve	1	
7	0306110	GT control unit hose 1/4 L=1500	1	
8	104-2008001	GT pneumatic valve unit	1	
9	0511081	Rubber pipe	1	
10	YC2-4198531	Pneumatic valve	1	
11	20200118	Air tank	1	
17	YC2-2012486	GT valve control	1	
18	YC2-2410288	GT pedal	1	
19	0204004	Nut M8 - GB/T889.1	1	
20	0203004	Nut M6 - GB52	3	
21	YC2-3008005	Limit stop screw support	1	
22	YC2-4298942	Spring	1	
23	0201014	Screw M6X20 - GB/T5783	1	
24	0201170	Screw M8X45 - GB/T794	1	
25	0213020	Pin 3X30	1	
26	0205016	Washer 14	1	
27	YC2-3010287	Valve unit support	1	

TAV.7.0	GT INFLATING DEVICE		
---------	---------------------	--	--

28	YC2-2009718	GT valve unit	1
29	0202033	Screw M6X20 - GB/T70.1	5
30	0202034	Screw M6X25 - GB/T70.1	2
31	0204001	Locking nut M4 - GB/T889.1	1
32	YC2-3001853	Valve control lever	1
33	0204003	Self-locking nut M6 - GB/T889.1	2
34	0201002	Screw M4X25	1
35	YC2-3000141	Spring	1
36	0306097	Rilsan hose 8X5 L=1000	1
37	C00AQ58000	Safety valve unit 3.5bar	1
38	0306097	Rilsan hose 8X5 L=850	1
39	0306097	Rilsan hose 8X5 L=400	1
40	0306095	Rilsan hose 6X4 L=400	2

TAV.8.0

INFLATOR+LUBRICATION GROUP

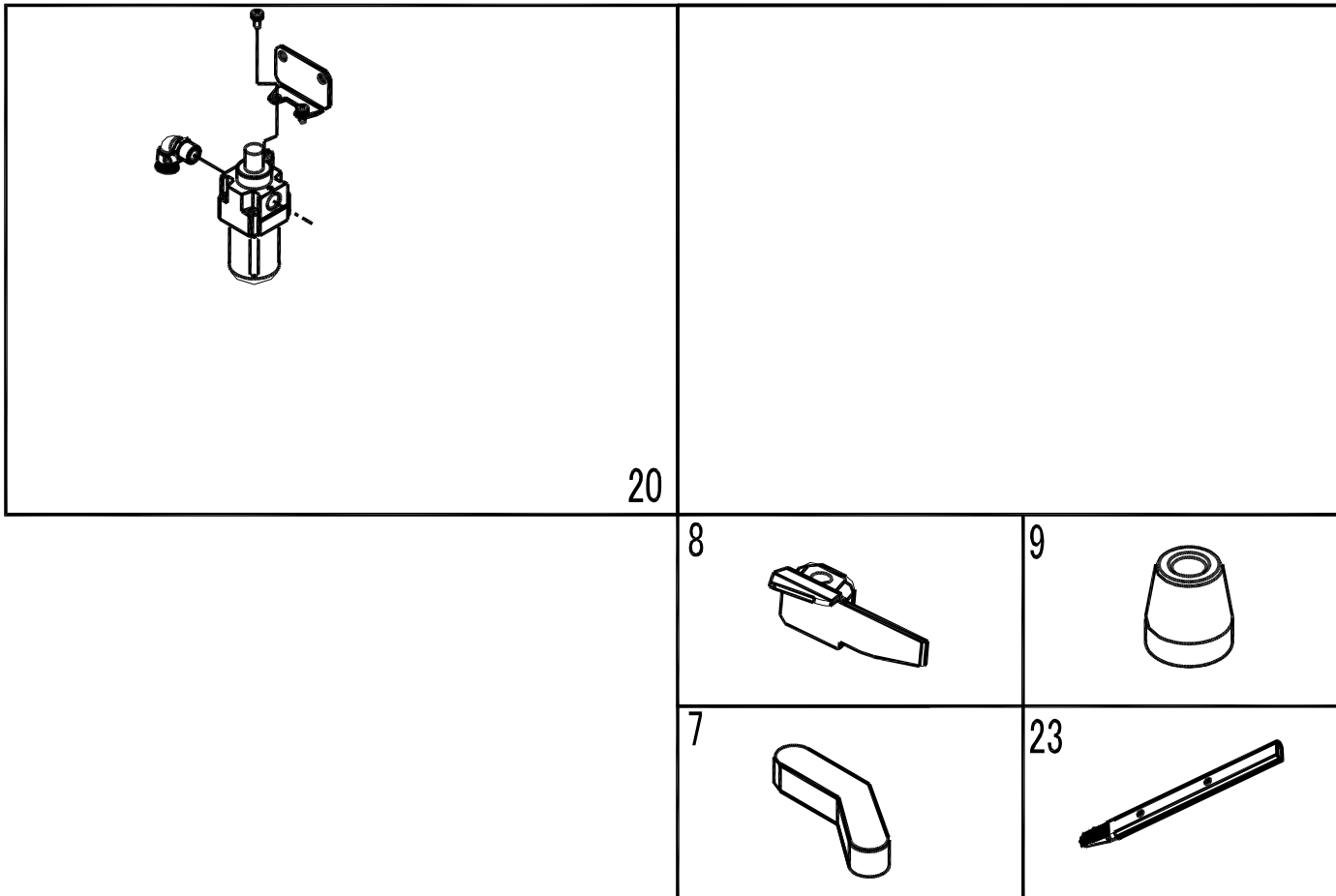

TAV.8.0	INFLATOR+LUBRICATION GROUP	
---------	----------------------------	--

ITEM	PART NO.	DESCRIPTION	QTY	REMARK
7	YC1-3013650	Plastic insert	3	
8	YC1-3006689	Plastic insert	3	
9	0215032	Peak roller	1	
20	41100001	Lubricator	1	
23	C00A000017	Bead lifting lever cover	1	



CORMACH S.r.l.
via A. Pignedoli, 2
42015 CORREGGIO (RE) ITALY
Tel. +39 0522 631274 - Fax +39 0522 631284
e-mail: cormach@cormachsrl.com
www.cormachsrl.com

